

Oct. 7, 1930.

P. BERNSTEIN

1,777,425

ELECTRIC CIPHER WRITING MACHINE.

Filed March 25, 1925 4 Sheets-Sheet 1

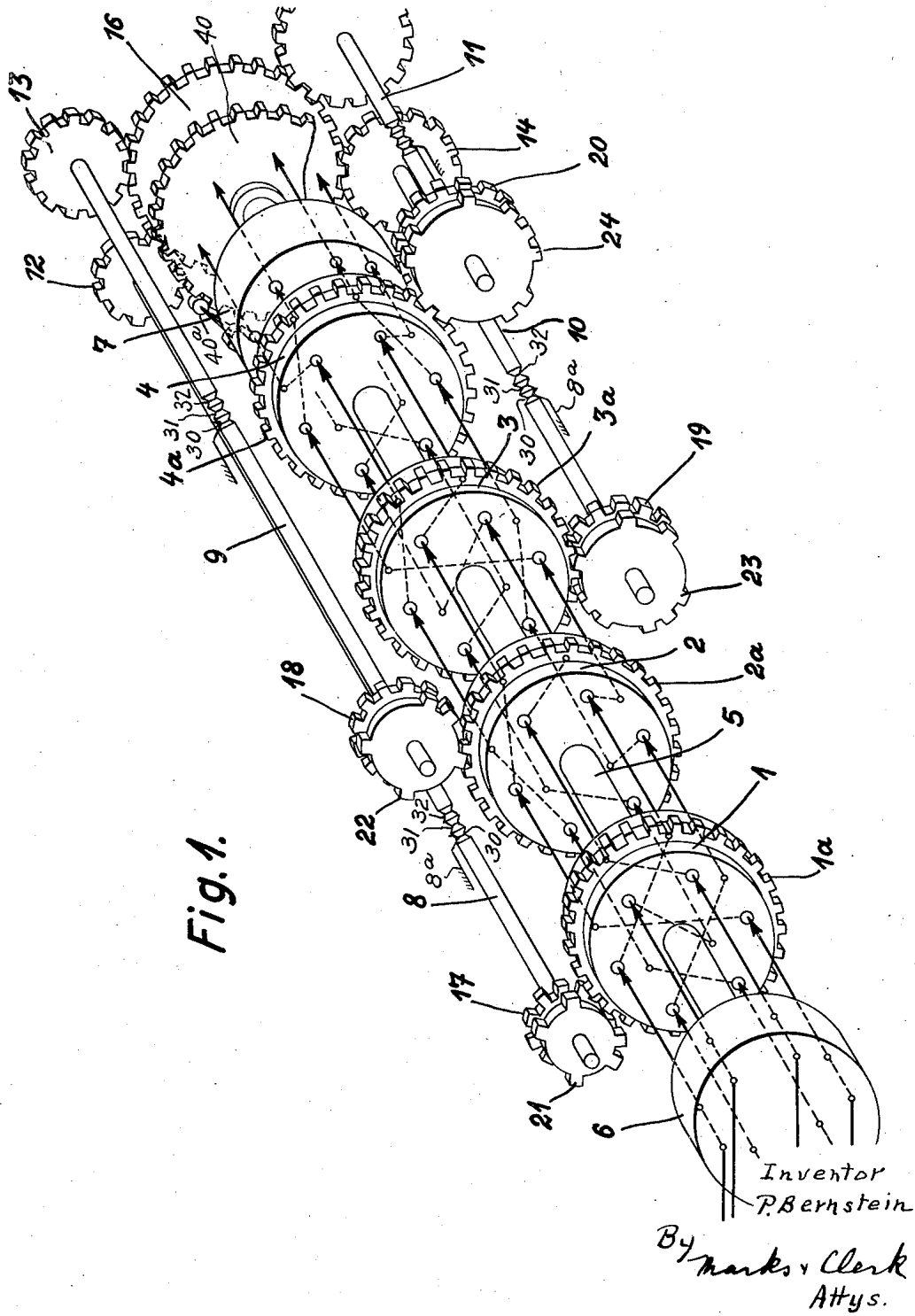

Fig. 1.

Inventor  
P. Bernstein

By Marks & Clerk  
Attys.

Oct. 7, 1930.

P. BERNSTEIN

1,777,425

ELECTRIC CIPHER WRITING MACHINE

Filed March 25, 1925 4 Sheets-Sheet 2

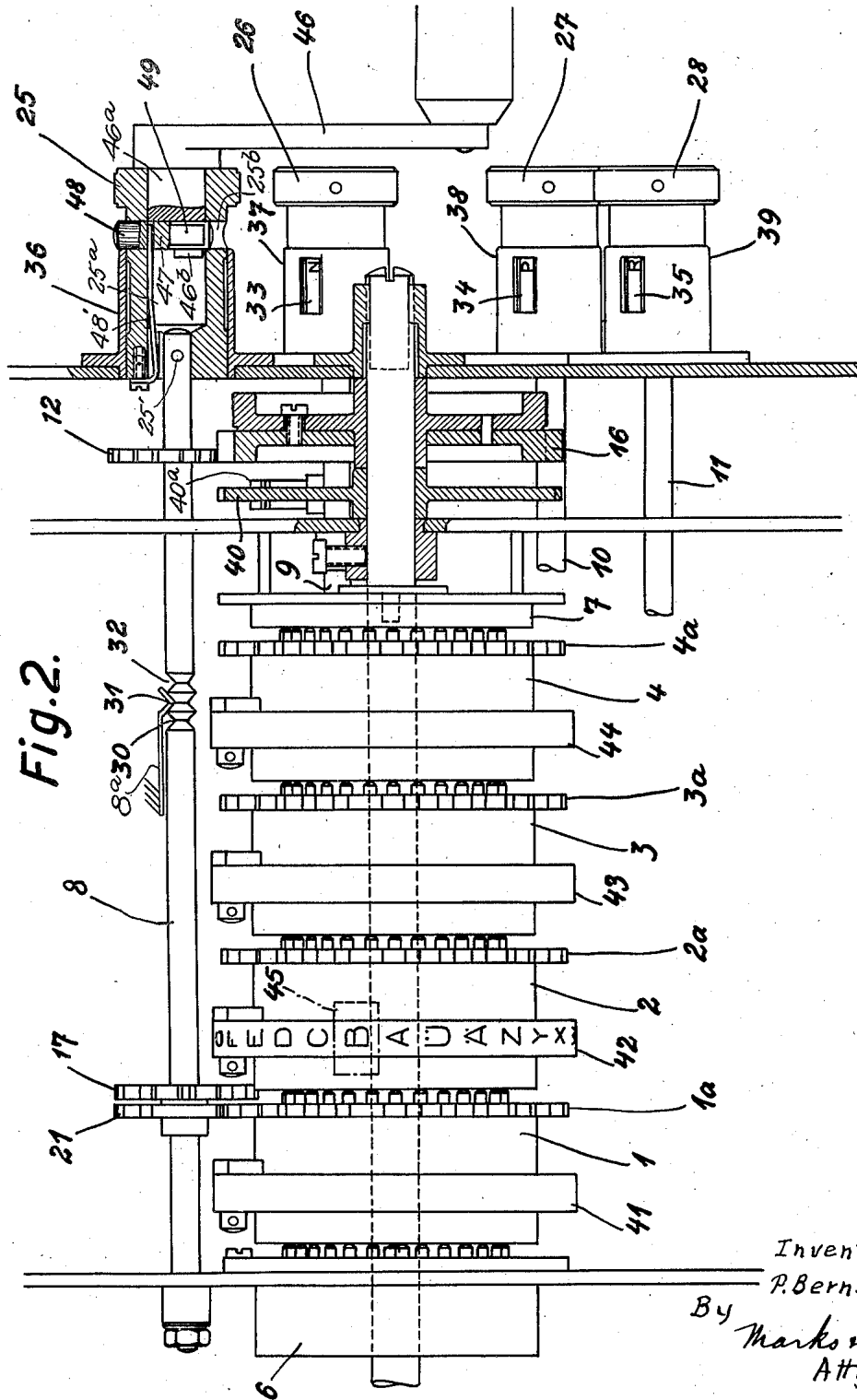

Inventor  
P. Bernstein  
By Marks & Clerk  
Attys.

Oct. 7, 1930.

P. BERNSTEIN

1,777,425

ELECTRIC CIPHER WRITING MACHINE

Filed March 25, 1925

4 Sheets-Sheet 3

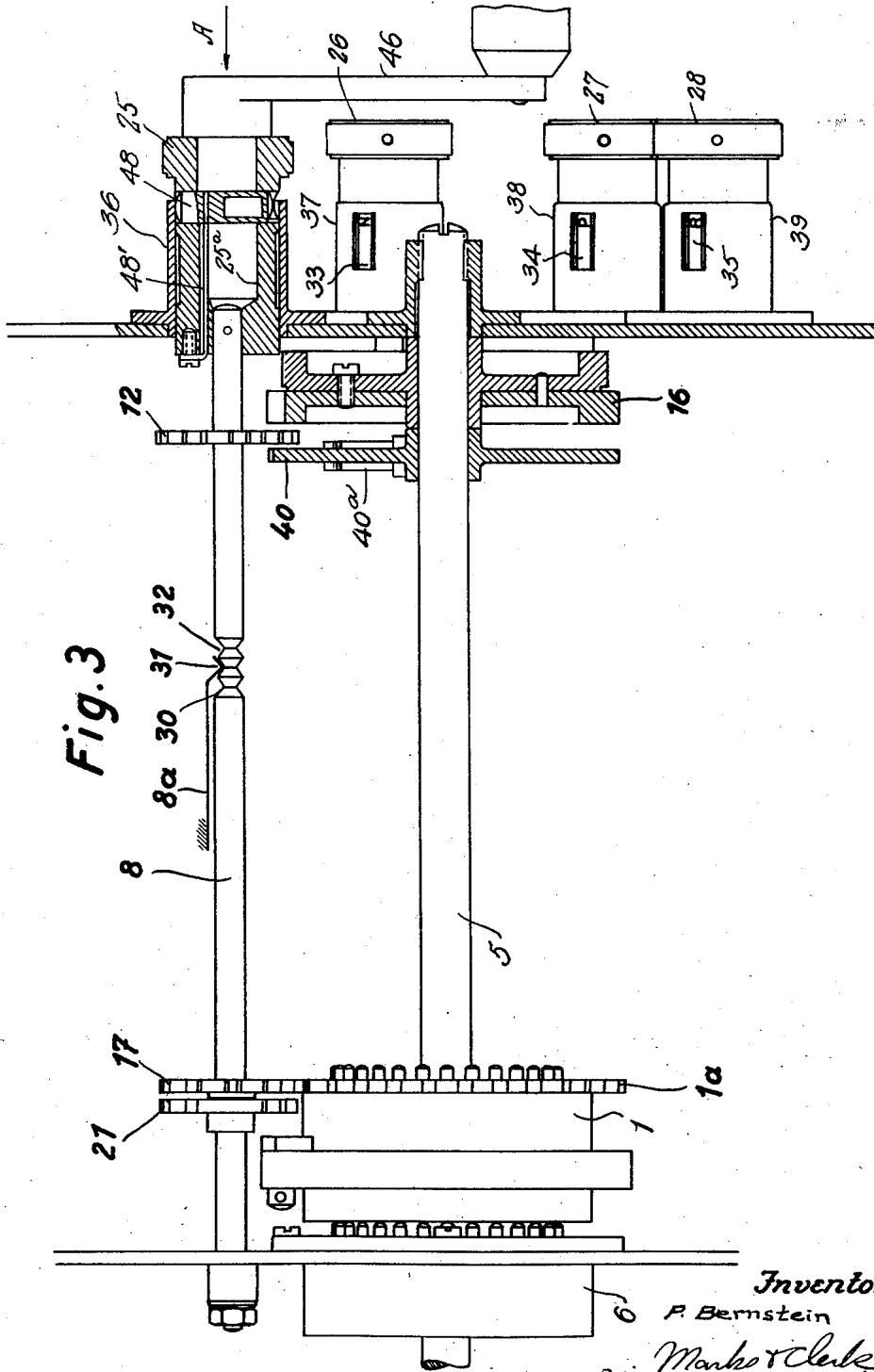



# UNITED STATES PATENT OFFICE

PAUL BERNSTEIN, OF BERLIN-CHARLOTTENBURG, GERMANY, ASSIGNOR TO THE FIRM  
CHIFFRIERMASCHINEN AKTIENGESELLSCHAFT, OF BERLIN, GERMANY

## ELECTRIC CIPHER-WRITING MACHINE

Application filed March 25, 1925, Serial No. 18,271, and in Germany March 25, 1924.

Cipher-writing devices for instance electric cipher-writing machines of the type disclosed in Patent No. 1,533,252, are known which comprise a plurality of ciphering cylinders having on the end faces a number of contacts by means of which they come in contact with one another. These revoluble ciphering cylinders are arranged between stationary end drums. The contacts of the one end face of the ciphering cylinders are connected with the contacts of the other end face as irregularly as possible by means of wires passing through the ciphering cylinders; the contacts of the one stationary end drum being connected with transmitters, for instance key contacts, while the contacts of the other stationary end drum are connected with signal devices, for instance with incandescent electric lamps or with a typewriting mechanism.

Owing to this arrangement the electric current travels, as when a transmitter point is operated, for instance by the depression of the key of the character *c*, in an irregular manner through the system of the ciphering cylinders (see Fig. 1) and makes a cipher character, for instance, the character *h* appear in the indicating or recording mechanism.

It has further become known to rotate one or more of the ciphering cylinders with reference to the others during the cipher-writing of a number of characters so that the system of the changing of characters is altered and at the next following depression of the character key *c*, for instance, the character *m* will be operated in the indicating or recording mechanism.

It may further be mentioned that there are as many contact points on the ciphering cylinders as there are signs to be changed, for instance 26 contacts corresponding with 26 letters of the alphabet. The ciphering cylinders will, in this case, resume the initial position after a comparatively few ciphering operations, so that, in the example selected, the character *c*, for instance will again cause the typing of the character *h*, e. g. the same period of ciphering will start again. The shorter a ciphering period is the easier will

it be to decipher the ciphered text by uninitiated persons.

According to the invention an arrangement is made which makes the ciphering periods very long so that the deciphering by uninitiated persons by observation of repeated changes of character is practically impossible. Care has to be taken, that the ciphering cylinders shall be easily brought into a predetermined position the one with regard to the others, that this position is rendered easily recognizable and that the ciphering cylinders can be easily brought back to any initial position.

An embodiment of the invention is shown, by way of example, in the accompanying drawings, in which

Fig. 1 is a perspective view of four ciphering wheels with their contact points and driving mechanisms. (For better illustrating the course of the current the ciphering wheels are shown at a slight distance from one another).

Fig. 2 shows a plan view of the ciphering-wheels and part of the driving and adjusting mechanism, partly in section.

Fig. 3 shows one of the four ciphering cylinders with their driving means and in a position different to that of Figs. 1 and 2.

Fig. 4 shows the same ciphering cylinder with the driving means, as shown in Fig. 3, but with a different position of the driving means to that shown in Figs. 1, 2 and 3.

In Fig. 1 only six contact points are shown for clearness sake, a greater number of contact points being indicated in Fig. 2 in accordance with the real construction of the machine.

The Fig. 3 shows the position of the driving wheels, indicated on the driving wheel 17, in which the driving wheel and the gap toothed wheel 21 are disengaged and the regularly toothed wheel 17 is in engagement with the gear wheel rim 1<sup>a</sup>. This position has for its object to turn the ciphering cylinder 1 by means of the knob 25 in order to adjust this ciphering cylinder relatively to the others in a predetermined position and thus adjust a new code key.

Fig. 4 shows how both driving wheels 21

and 17 are completely out of engagement with the gear wheel rim 1<sup>a</sup>, whereas the toothed wheel 12 now engages with the toothed wheel 40. This position has for its object to adjust the gap toothed wheels in a predetermined position relatively to their respective gear wheel rims and thereby to adjust a certain code key.

The toothed wheel 40 serves to maintain the proper position of the teeth of the driving wheel 17 relatively to the gaps of the gear wheel rim 1<sup>a</sup> so long as the two toothed wheels are mutually disengaged.

In the form of construction illustrated by way of example four ciphering wheels 1, 2, 3 and 4 are arranged between stationary end drums 6 and 7 so that said ciphering wheels can rotate upon shaft 5. These ciphering wheels have each a toothed crown 1<sup>a</sup>, 2<sup>a</sup>, 3<sup>a</sup>, 4<sup>a</sup>. Four shafts 8, 9, 10, 11 are arranged outside the ciphering wheels, each shaft carrying a spur wheel 12, 13, 14, 15 respectively and all these spur wheels are driven at the same time from a common driving element, for instance a spur wheel 16. On the end of each shaft 8, 9, 10, 11 opposite to the spur wheels 12, 13, 14, 15 a regular toothed wheel 17, 18, 19, 20 respectively is arranged and further at the side of each regular toothed wheel a mutilated toothed wheel 21, 22, 23, 24 respectively which has only a few teeth and very wide gaps between the teeth. The shafts 8, 9, 10, 11, are adapted to be moved in longitudinal direction to be adjusted into different positions with the aid of knobs 25, 26, 27, 28 (Fig. 2) fixed on the ends of the shafts on which the spur wheels are keyed, each shaft having three notches 30, 31, 32 with one of which a suitable locking element 8<sup>a</sup> engages to lock the shaft in the adjusted position. Of the three positions of each shaft 8, 9, 10, 11, two positions correspond each to a drive condition for the code wheels, namely a drive by means of the mutilated gears 21, 22, 23, 24 and a drive by means of the regularly toothed gears 17, 18, 19, 20 while the third position renders possible completely free rotation of the said shafts without any connection with the code wheels for the purpose of adjustment of the mutilated gears before their connection with the code wheels. The actual position of the driving shafts is indicated by marks, for instance characters, appearing either at the right, at the left or at the middle in windows 33, 34, 35 arranged in sleeves 36, 37, 38 and 39 mounted on the knobs 25, 26, 27, 28.

The divisions of the driving wheels 12, 13, 14, 15 and consequently of the regular toothed wheels 17, 18, 19, 20 and the mutilated toothed wheels 21, 22, 23, 24 correspond, according to the invention, to prime numbers or numbers which have no common factor. For the divisions of the wheels men-

tioned the numbers 11, 15, 17, 19 have for instance been selected.

By reason of this arrangement the period of coding is particularly long since for complete rotation of all of the adjusting shafts 8, 9, 10, 11, e. g. the adjusting of the same to the original initial position, as many single steps are required as correspond to the product of these members, e. g.  $11 \times 15 \times 17 \times 19 = 53295$ . The division of the toothed wheels for the driving of the ciphering wheels is further selected, according to the invention, so that it is not a multiple of the divisions of the ciphering wheels (contact number, for instance 26). Consequently the total period of the ciphering is  $11 \times 15 \times 17 \times 19 \times 26 = 1385670$ .

If, for each ciphering, one should start from the same initial position the ciphering periods would repeat themselves every time accurately in the same manner, e. g. the succession of the alterations of changing would always be the same in this period. In order to avoid this the ciphering is started every time or after a certain number of cipherings have been done, with a new initial position of the driving wheels.

When the shafts of the driving wheels are at the extreme left position so that neither the regular toothed wheels nor the mutilated toothed wheels are in gear with the toothed crowns of the ciphering wheels, each shaft can be rotated independently of the others with the aid of its knob so that the driving wheels can be brought to any desired initial position indicated by the characters appearing in the windows of the knob-sleeves 36, 37, 38, 39.

When the shafts 8 to 11 are shifted in such a manner that the fully toothed wheels and the mutilated wheels for instance, 17 and 21, respectively, of shaft 8 (Fig. 2) are disengaged from spur gears on the cipher cylinders, for instance, gear 1<sup>a</sup> of the cipher cylinder 1 (Fig. 2), it is possible that when the shafts are reshifted one tooth of the full gear will not enter into a gap of the corresponding spur gear of the ciphering cylinder, but will abut against the side thereof. This difficulty is overcome in the following manner:

Adjacent the driving gear 16, which is in engagement with a corresponding toothed wheel 12 (Fig. 2) as long as the mutilated gears are in engagement with the corresponding spur gear of the ciphering cylinder, an auxiliary gear 40 is provided, which can be turned manually corresponding to the tooth spacing and which has the same number of teeth as the driving gear 16, there being a stop device 40<sup>a</sup> engaged with the teeth of the gear 40 to maintain the same in stepped position. When in the shifting of the shaft 8 (Fig. 2) to the left, the gear 12 comes out of engagement with the driving gear 16, so that it is located between the

latter and the auxiliary gear 40, the fully toothed gear is in engagement with the spur gear 1<sup>a</sup> of the cipher cylinder 1. As the shaft 8 is further shifted towards the left-hand side, the fully toothed gear 17 comes out of engagement with the spur gear 1<sup>a</sup>. However, before this takes place the gear 12 engages the gear 40, and the shaft 8, is, therefore, held in the proper position and cannot rotate. When the shaft 8 again is reshifted towards the right-hand side the teeth of the fully toothed gear 17 must positively engage the spaces between the teeth of the spur gear 1<sup>a</sup>, and proper meshing of the gear teeth is assured. The same function which has been just described in regard to shaft 8 (Fig. 2) refers, of course, also to the other shafts 9 to 11.

If the knobs are pulled and the driving shafts shifted to the right the mutilated toothed wheels are brought in engagement with the toothed crowns of the ciphering wheels.

When the ciphering wheels have to be adjusted to a predetermined initial position it is only necessary to bring the regular toothed wheels in gear with the toothed crowns of the ciphering wheels by shifting the knobs into the middle position, whereupon, by rotating the knobs and consequently the driving shafts, a predetermined position can be given to each individual ciphering wheel. To indicate these positions rings 41, 42, 43, 44 respectively are fixed on the ciphering wheels which rings are marked with characters, as indicated on the ring 42 one of which appears, according to the position to which the ciphering wheel has been adjusted in a window 45 arranged for this purpose.

In order to bring the ciphering wheels into a predetermined position with regard to one another that is, to adjust the code device to a certain code key, so that certain letters appear in the windows 45, the following device is provided.

A crank 46 can be inserted into one of the adjusting knobs, for instance into knob 25, but only when this knob is in such a position that the mutilated toothed wheel is in gear with the toothed crown of the ciphering wheel. In this case the spur wheel 12 is in engagement with the common driving wheel 16, and when knob 25 is rotated all the shafts 8, 9, 10, 11 and consequently all the ciphering wheels will be adjusted with regard to one another through the intermediary of said mutilated toothed wheels.

The shaft 8 is secured to the knob 25 by a pin 25' so that the shaft also rotates when the knob 25 is turned. The knob 25 has internally a longitudinal bore 25<sup>a</sup> and also a transverse bore 25<sup>b</sup>. The transverse bore 25<sup>b</sup> has a substantially less diameter than the longitudinal bore 25<sup>a</sup>. There is inserted in the transverse bore a pin 48, which is normally

held by a spring 48' in such a manner that the knob of the pin bears against the sleeve 36. The said knob 48 has a flattened member 49 which, however, does not extend over the full height of the inner bore 25<sup>a</sup> of the knob 25. The crank 26 has a cylindrical member 46<sup>a</sup> which changes into a bifurcated member 46<sup>b</sup>. This bifurcated member is only so high that it corresponds with the flattened member 49 of the pin 48. When inserting the crank of the cylindrical member 46<sup>a</sup> in the knob 25, the bifurcated member 46<sup>b</sup> engages with the pin 48 on the flattened part so that when turning the crank, the knob 45 and also the shaft 8 is turned. Since in the operative position (Fig. 2) the toothed wheel 12 engages with the toothed wheel 16 and the toothed wheel 16 again engages with the toothed wheels 13, 14, 15, all shafts 8, 9, 10, 11 will be turned when the crank 46 is turned.

If the shaft 8 is to be brought out of the position according to Fig. 2 into the position according to Fig. 3, the knob 25 is taken hold of by the hand and advanced in the direction of the arrow A. This is, however, only possible when the pin 48 is first pressed inwardly so as to permit the said displacement. The position of the knob 25 is shown in Fig. 3.

If the knob 25 is to be further advanced in the direction of the arrow A, it occupies the position shown in Fig. 4.

I claim:—

1. An arrangement for electric ciphering machines comprising in combination, a number of ciphering wheels, contact points on both sides of said ciphering wheels, a transmitting device, a receiving device, irregular electric connections between said transmitter and said receiver and passing through said ciphering wheels, a toothed crown on each ciphering wheel, and driving wheels engaging with said toothed crowns and having each a different number of teeth without common factor.

2. An arrangement for electric ciphering machines comprising in combination, a number of ciphering wheels, contact points on both sides of said ciphering wheels, a transmitting device, a receiving device, irregular electric connections between said transmitter and said receiver and passing through said ciphering wheels, a toothed crown on each ciphering wheel, and driving wheels engaging with said toothed crowns and having each a different number of teeth according to prime numbers.

3. An arrangement for electric ciphering machines comprising in combination, a number of ciphering wheels, contact points on both sides of said ciphering wheels, a transmitting device, a receiving device, irregular electric connections between said transmitter and said receiver and passing through said ciphering wheels, a toothed crown on each ciphering wheel, and driving wheels engag-

ing with said toothed crowns and having each a different number of teeth without common factor, the different numbers of teeth being selected so that they are not a multiple of the number of feeding steps necessary for one revolution of the ciphering wheels.

4. An arrangement for electric ciphering machines comprising in combination a number of ciphering wheels, contact points on both sides of said ciphering wheels, a transmitting device, a receiving device, irregular electric connections between said transmitter and said receiver and passing through said ciphering wheels, a gap toothed wheel for each ciphering wheel, a regular toothed wheel for each ciphering wheel, a common shaft for each gap and regular toothed wheel, said shaft being shiftable in longitudinal direction, means at the other ends of said shafts for rotating and shifting said shafts, and means for indicating the actual position of said shafts and for locking said shafts in the actual position.

5. An arrangement for electric ciphering machines comprising, in combination, a number of ciphering wheels, contact points on both sides of said ciphering wheels, a transmitting device, a receiving device, irregular electric connections between said transmitter and said receiver and passing through said ciphering wheels, a gap toothed wheel for each ciphering wheel, a regular toothed wheel for each ciphering wheel, a common shaft for each gap and regular toothed wheel, said shaft being shiftable in longitudinal direction, means at the other ends of said shafts for rotating and shifting said shafts, and means for indicating the actual position of said shafts and for locking said shafts in the actual position, a common driving wheel for the shafts of all the driving wheels of the ciphering wheels, said common driving wheel acting upon the spur wheels of said shafts and being disengaged of said spur wheels when said shafts are shifted out of the driving position.

6. An arrangement for electric ciphering machines comprising in combination, a number of ciphering wheels, contact points on both sides of said ciphering wheels, a transmitting device, a receiving device, irregular electric connections between said transmitter and said receiver and passing through said ciphering wheels, a gap-toothed wheel for each ciphering wheel, a regular toothed wheel for each ciphering wheel, a common shaft for each gap and regular toothed wheel, said shaft being shiftable in longitudinal direction, means at the other ends of said shafts for rotating and shifting said shafts, and means for indicating the actual position of said shafts and for locking said shafts in the actual position, a common driving wheel for the shafts of all the driving wheels of the ciphering wheels, said common driving wheel

acting upon the spur wheels of said shafts and being disengaged of said spur wheels when said shafts are shifted out of the driving position, an auxiliary toothed wheel besides the common driving wheel, gearing when said driving shaft is out of the working position, with the spur wheels of each driving shaft, which, when the shafts are in the working position, gear with said common driving wheel and permit thus only a stepwise shifting of said driving shafts from tooth to tooth.

7. An arrangement for electric ciphering machines comprising in combination a number of ciphering wheels, contact points on both sides of said ciphering wheels, a transmitting device, a receiving device, irregular electric connections between said transmitter and said receiver and passing through said ciphering wheels, a gap toothed wheel for each ciphering wheel, a regular toothed wheel for each ciphering wheel, a common shaft for each gap and regular toothed wheel said shaft being shiftable in longitudinal direction, means at the other ends of said shafts for rotating and shifting said shafts, and means for indicating the actual position of said shafts and for locking said shafts in the actual position, a knob at the end of each shaft for rotating and shifting said shafts, sleeves, one for each knob, enclosing a portion of said knob, and a window in each sleeve behind which a sign appears to indicate the position of said shaft.

8. An arrangement for electric ciphering machines comprising in combination a number of ciphering wheels, contact points on both sides of said ciphering wheels, a transmitting device, a receiving device, irregular electric connections between said transmitter and said receiver and passing through said ciphering wheels, operating means for each ciphering wheel and for moving said ciphering wheels after each ciphering sign in a different manner with regard to one another, rings on said ciphering wheels each ring being marked with a number of characters corresponding to the number of contact points, one of said characters appearing in a window of the ciphering device and indicating the actual position of the ciphering wheels.

In testimony whereof I affix my signature.  
PAUL BERNSTEIN.

70  
75  
80  
85  
90  
95  
100  
105  
110  
115  
120  
125  
130