

Hello Luca,

You can, without soldering dismount your E52. Pull-out the long band selector shaft first. Make yourself a special tool, by which means you can de-screw the tiny contacts, after you have removed the upper valve modules (two RF stages + mixer/oscillator). Some Kölns have an antenna wire to the first FR-coil section.

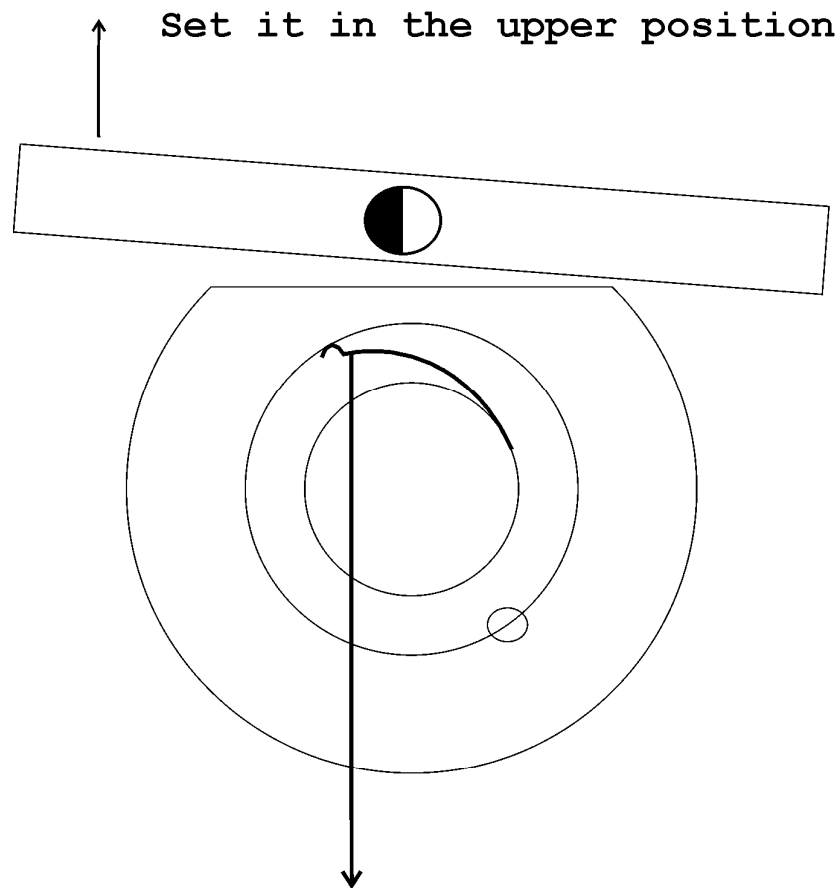

By means of a solid, but small tool bending it downwards. Watch that your grip is solid. Remove now the glass-scale. Then slowly release its tension.

After the loading spring has been moved downwards, you carefully can take out the glass scale (removing it). Be careful with releasing spring tension, you otherwise may destroy it! Be sure that the flat section of the glass disk is in line with the lens mechanism. My drawing is not entirely in optimal position. But I trust that you understand its meaning.

Air pressure is an open question. Never use too much power. Soft air flow is, nevertheless, allowed. Clean carefully the condenser contacts by means of a high quality contact spray, like 'Kontakt 61'. Prevent that its content comes at ceramic faces, as this may cause HF leakage.

Be most careful by dismantling the gear mechanisms! Be most sure that all the appropriate markings are good visible on both sides of the spring-loaded gearwheels!

Please let me know whether you understood the meaning of this message.

Best wishes,

Arthur